

# New facilities for floating events

Water, a bit of sunshine, the open air: the basic ingredients for the 'good life'. The perfect combination to get everyone in the mood and bring people together. Despite this there are few hospitality facilities where people can enjoy the outdoors and the waterside on a large scale, whenever the sun breaks through.

The idea behind this? For some years there has been a high demand for flexible facilities for parties and other events at the waterside, or on the water. Demand is driven by watersports companies, the business world and events organisers, and aimed at the top end of the sector, with every element of luxury...and the right hospitality facilities. Terraces and other facilities on or at the waterside are often scarce. The Watercafés can be used for a party with a great view, or a marketing presentation offering a different perspective.

The design consists of floating units which can be coupled together in various combinations. The pontoons have a standard measurement of 20 by 8 metres (roughly 60 by 24 ft) and are entirely self-sufficient. They can be towed, have their own anchor system, and can be moored almost anywhere without need for a licence. In addition, the position of the pontoons can be adjusted daily to allow its terrace to be in full sunshine and...out of the wind.

There is ample storage space for hospitality supplies in the hold of the pontoons. An energy generating set is also positioned there. The concept of an autonomous energy supply is a speciality of on-board

energy experts Victron Energy. The on-board energy system, with several inverters, effortlessly selects the most efficient combination of available energy supplies: solar panels on the roof, a diesel generator in the hold, a quayside supply or a professional battery bank (each roughly 1500 AmpH). The energy capacity has been calculated to provide a minimum of two days' continuous smooth operation. In reality usage is unlimited, provided the diesel tank is topped up.

Next year 4-5 Wettertents will be built. Naturally, if it's a hit, production will increase. It looks as though this will be the case, given the extremely limited number of hospitality licences given for waterside locations. The pontoons can be delivered made-to-measure: a café; a lounge pontoon; in the form of an open terrace; a covered conference room, amongst others. The Watercafés can be moored anywhere for public presentations, marketing events, a wedding, or just for a great party with friends. It's a stylish idea which will appeal to any lover of the outdoors. A party is not complete unless the Watercafé has been invited...



**victron energy**  
BLUE POWER

# Self-regulating on-board system (see diagram):



3 x 5Kw Quattro system

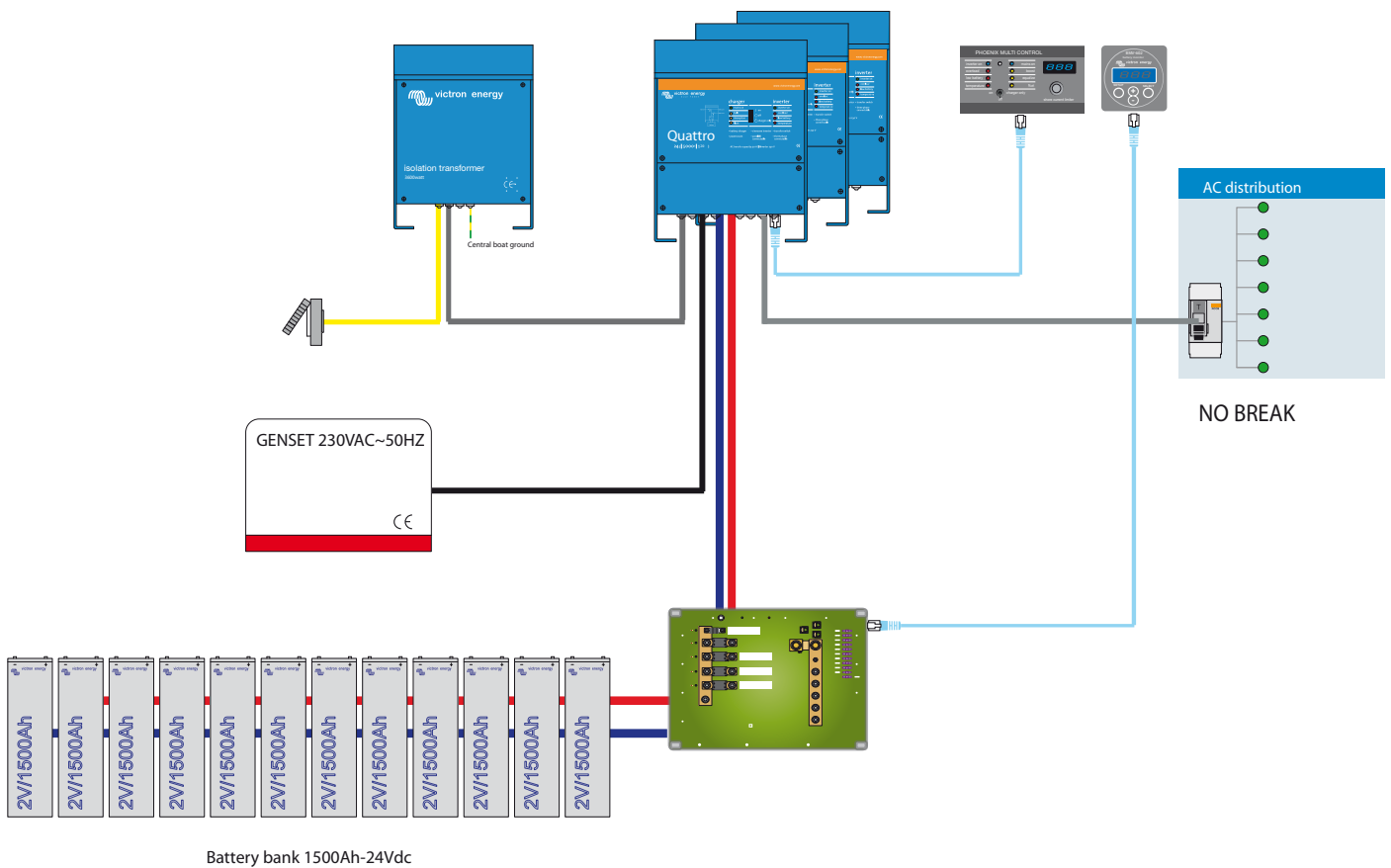

Battery bank 1500Ah-24Vdc



- 3 Quattro's supply the entire system, based on quayside energy and a 7kva Westerbeke genset.
- The system activates the generator in cases of peak demand or empty batteries. The system is supplied and the batteries recharged.
- The batteries 2V cells (24V 1500 Ah) offer capacity for a full day
- There is always sufficient energy (and silence), on demand.
- As a consequence of the self-regulating system there is no need for technically qualified crew.
- The system is free of worry. You moor the Watercafé, ensure there is enough fuel and that's it.